

ERA Horizon Standard Friction Hinges

Ordering Details

Top Hung		Part No.		
Size		13mm	15mm	17mm
210mm	8"	WFHZF0813TB	WFHZF0815TB	WFHZF0817TB
261mm	10"	WFHZF1013TB	WFHZF1015TB	WFHZF1017TB
311mm	12"	WFHZF1213TB	WFHZF1215TB	WFHZF1217TB
414mm	16"	WFHZF1613TB	WFHZF1615TB	WFHZF1617TB
516mm	20"	WFHZF2013TB	WFHZF2015TB	WFHZF2017TB
616mm	24"HD	WFHZF2413TB	WFHZF2415TB	WFHZF2417TB
616mm	24"HD ^{Non Restricted}	WFHZF2413TBNR	WFHZF2415TBNR	WFHZF2417TBNR

Side Hung		Part No.		
Size		13mm	15mm	17mm
311mm	12"	WFHZF1213SB	WFHZF1215SB	WFHZF1217SB
414mm	16"	WFHZF1613SB	WFHZF1615SB	WFHZF1617SB

Dimensions

Size (mm)	Nom Inch	Dim A	Dim B	Dim C1	Dim C2	Dim C3	Dim C4	Dim C5
210mm	8"	204	145.4	210.2	158.7	65.2	-	34.2
261mm	10"	255.8	199.4	261.7	191.2	79.8	-	34.2
311mm	12"	305.4	188.9	311.2	233.7	85.2	-	34.2
414mm	16"	407.1	210.7	414.2	266.2	114.1	65.2	34.2
516mm	20"	510	350.5	516	331.4	215.2	73	34.2
616mm	24"HD	609.8	442.3	616	381.2	261.7	72.2	34.2

Weights and Sash Sizes

Size (mm)	Nom Inch	Approx. Opening Angle	Max Width (mm)	Max Height (mm)	Max Sash Weight (kg)
Top Hung					
210mm	8"	56°	-	350mm	14kg
262mm	10"	75°	-	400mm	18kg
311mm	12"	75°	-	550mm	22kg
414mm	16"	75°	-	780mm	23kg
516mm	20"	40°	-	1100mm	28kg
616mm	24"HD	32°	-	1300mm	48kg
Side Hung					
311mm	12"	75°	600mm	-	24kg
414mm	16"	75°	700mm	-	26kg

Packaging

Size	Box Quantity	Box Weight (13mm)	Box Weight (15mm)	Box Weight (17mm)
Top Hung				
8"	210mm	30	9.0kg	9.1kg
10"	261mm	30	10.9kg	11.1kg
12"	311mm	30	12.9kg	13.1kg
16"	414mm	25	13.4kg	13.5kg
20"	516mm	20	13.1kg	13.3kg
24"HD	616mm	10	5.9kg	5.9kg
Side Hung				
12"	311mm	30	14.3kg	14.3kg
16"	414mm	25	12.0kg	12.0kg

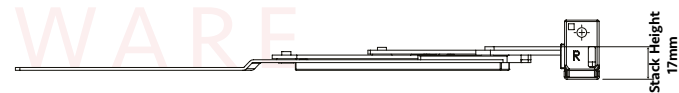
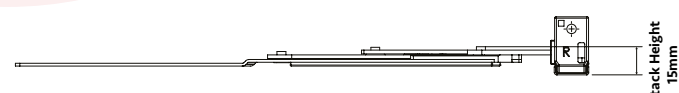
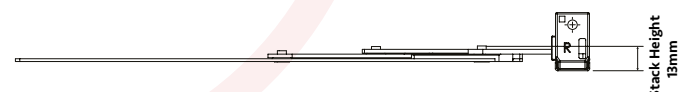
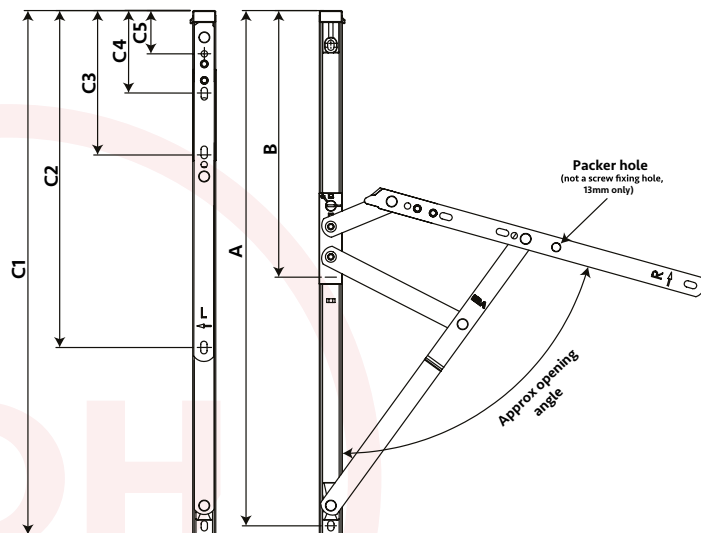

All dimensions are in mm.
ERA reserves the right to change specification without notice.
It is the responsibility of the window manufacturer to ensure that the finished product meets any required safety and performance specification

Maintenance

All moving parts should be lightly lubricated using a light non-acidic mineral oil (e.g. "3 in 1") twice per year and the surface cleaned with a soft damp cloth. The product may need to be adjusted and fixings tightened to ensure a satisfactory operation.