

FITTING INSTRUCTIONS

KIT AND DOOR SPECIFICATION

Kit Short Code	Door Configuration	Kit Contents	Max. Door Height	Max. Door Width	Max. Door Thickness	kg
HRP2/1	2+1	1 x two door kit, 1 x one door pivot kit	3000mm	838mm	35-44mm	40kg
HRP3/0	3	1 x three door kit	3000mm	838mm	35-44mm	40kg
HRP3/1	3+1	1 x three door kit, 1 x one door pivot kit	3000mm	838mm	35-44mm	40kg
HRP3/2	3+2	1 x three door kit, 1 x two door kit	3000mm	838mm	35-44mm	40kg
HRP3/3	3+3	2 x three door kit	3000mm	838mm	35-44mm	40kg

KIT CONTENTS

Note: Track Not Included

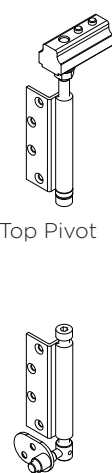
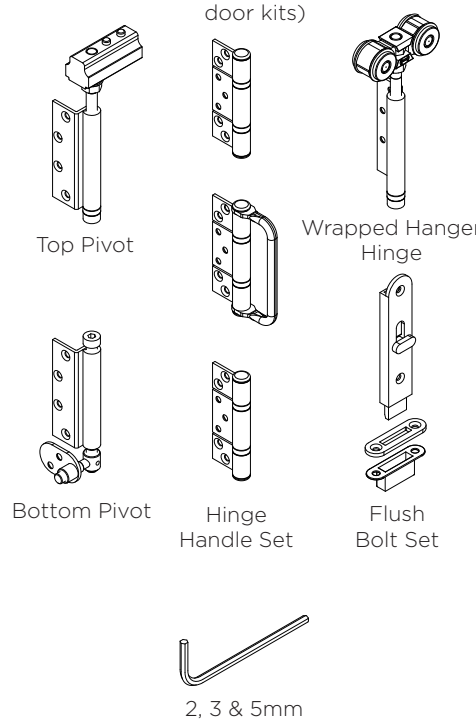
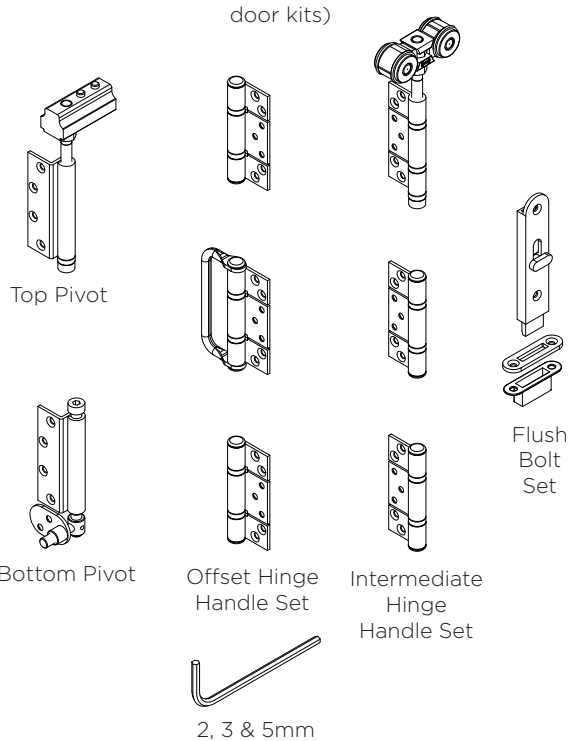
1 Door Pivot Kit (Not for sale individually. For use with 2 and 3 door kits)	2 Door Kit (Not for sale individually. For use with 2 and 3 door kits)	3 Door Kit (Can be sold individually and for use with 3 door kits)
 <p>Top Pivot</p> <p>Bottom Pivot</p>	 <p>Top Pivot</p> <p>Bottom Pivot</p> <p>Hinge Handle Set</p> <p>Hinge Bolt Set</p> <p>Wrapped Hanger Hinge</p> <p>Flush Bolt Set</p> <p>2, 3 & 5mm</p>	 <p>Top Pivot</p> <p>Bottom Pivot</p> <p>Offset Hinge Handle Set</p> <p>Intermediate Hinge Handle Set</p> <p>Flush Bolt Set</p> <p>2, 3 & 5mm</p>

It is recommended that a light smear of general purpose grease is applied to all bolts prior to assembly.

TOOLS REQUIRED

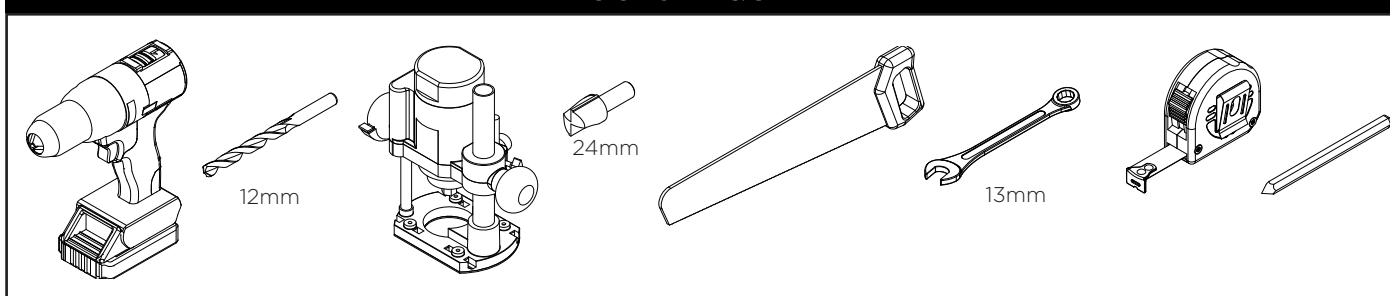

SYSTEM OVERVIEW AND DOOR CONFIGURATIONS

Folding Direction

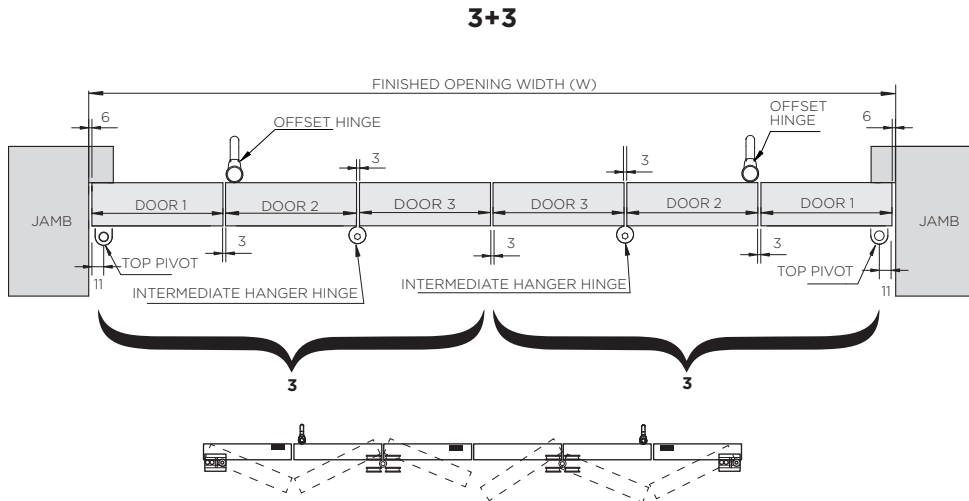
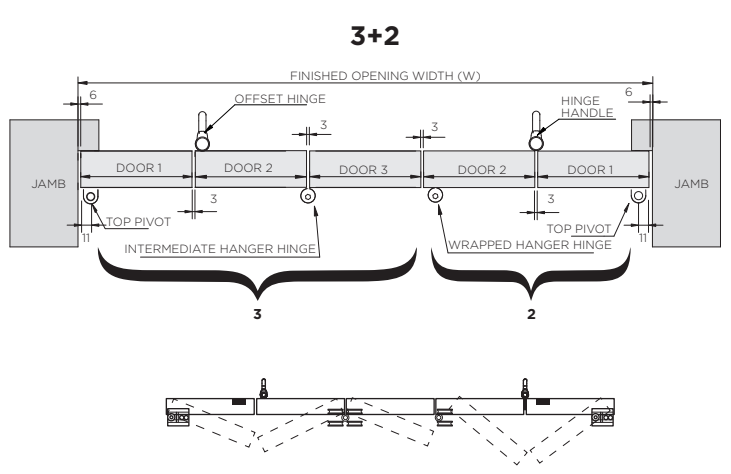
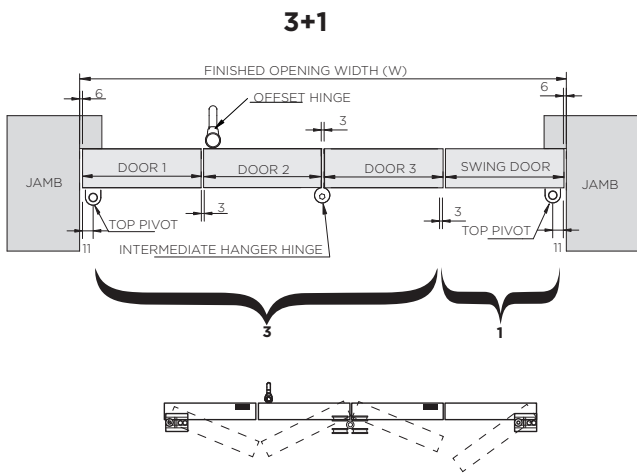
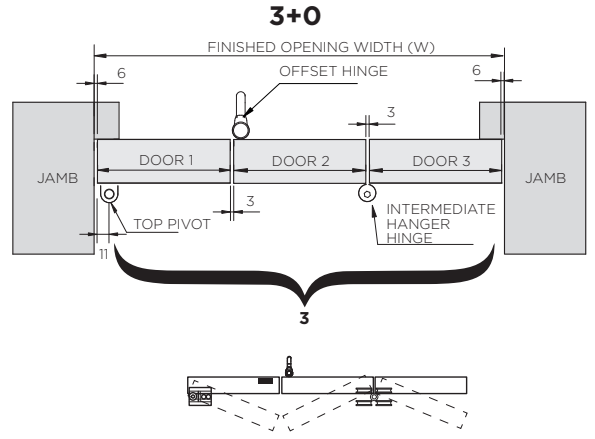
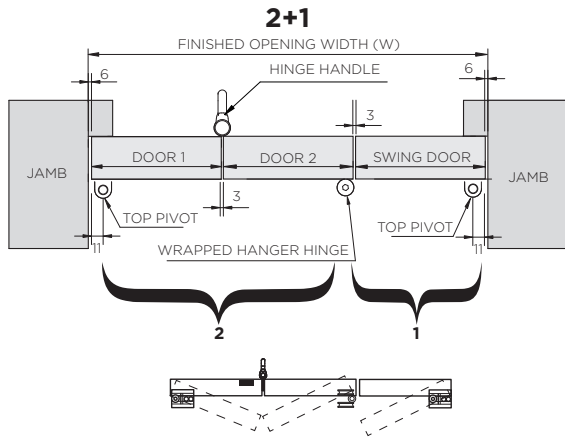

 = Flush Bolt

FRAME DIMENSIONS

1

Diagram 1 - Section View

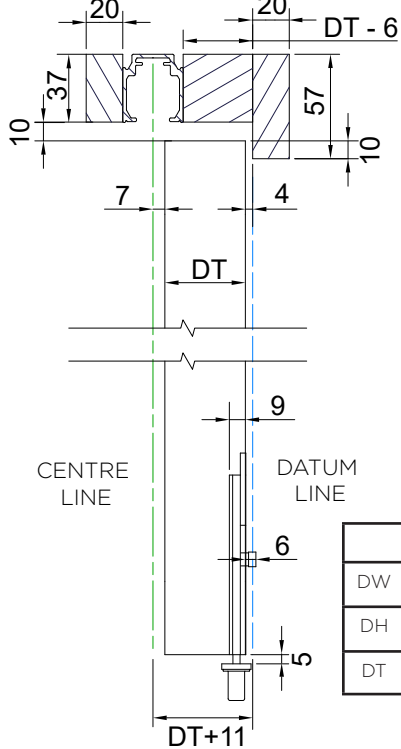
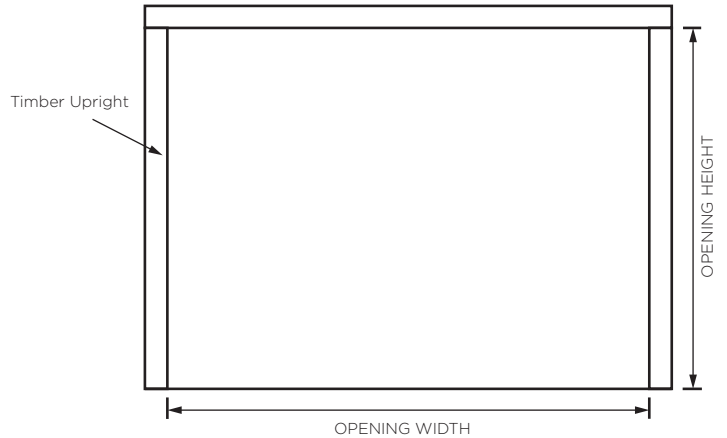

Diagram 2 - Elevation View



Opening Size Formula

DOOR CONFIGURATION	OPENING WIDTH	OPENING HEIGHT
2+1	$(DW \times 3) + 18$	DH+52
3+0	$(DW \times 3) + 18$	
3+1	$(DW \times 4) + 21$	
3+2	$(DW \times 5) + 24$	
3+3	$(DW \times 6) + 27$	

KEY	
DW	Door Width
DH	Door Height
DT	Door Thickness

Note: Ensure opening is square, level and all load bearing areas are suitable for weight of system. Ensure there is sufficient strength in structure above the opening to take concentrated weight of doors when open. Roomflex Pro provides +/- 5mm of horizontal adjustment. Ensure doors are measured accurately prior to installation.

2

USING OPENING WIDTH SHOWN IN TABLE ABOVE, CUT TRACK TO REQUIRED LENGTH. ENSURE 5MM HOLE 50MM - 100MM FROM END OF THE TRACK.

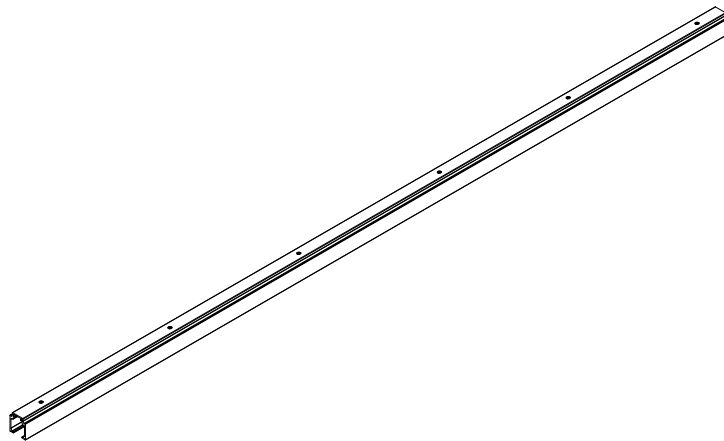

3

UNSCREW TOP PIVOT BLOCK(S) FROM TOP PIVOT.

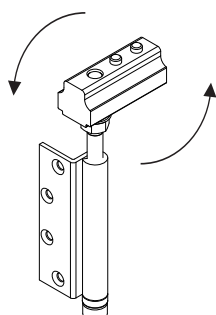

4

2+1 AND 3+2 CONFIGURATIONS ONLY
UNSCREW HANGER BODY FROM WRAPPED HANGER HINGE.

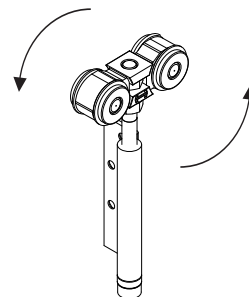

5 SLIDE PIVOT BLOCK(S) AND HANGER(S) INTO TRACK.

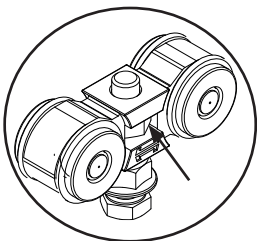
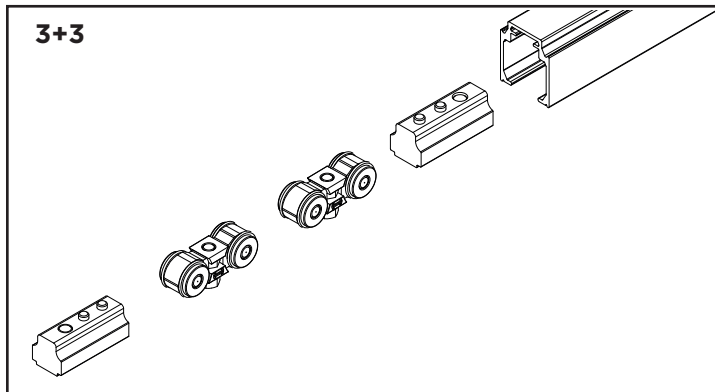
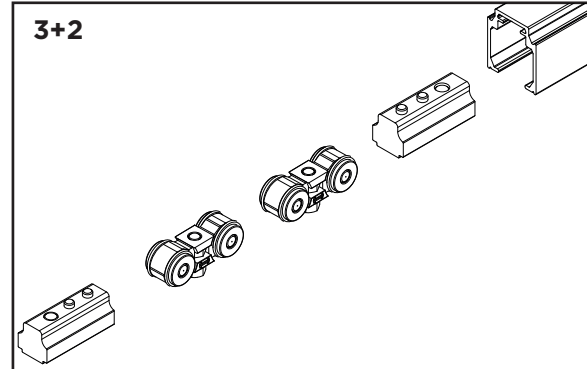
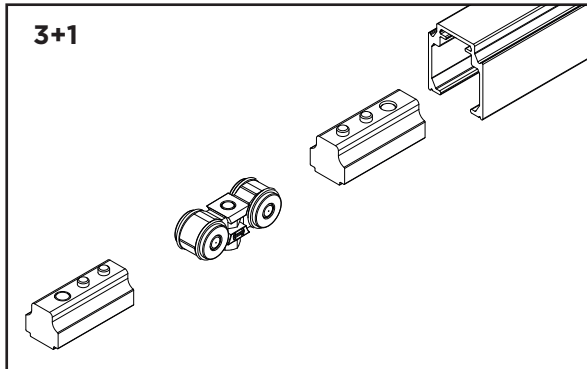
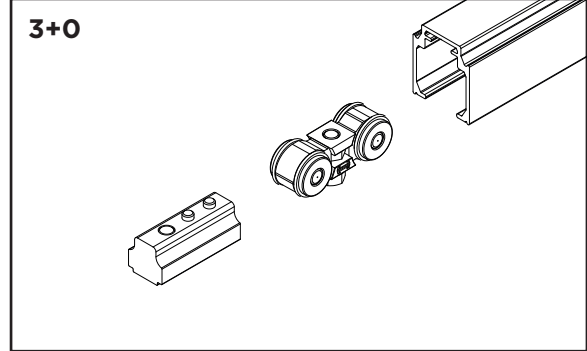
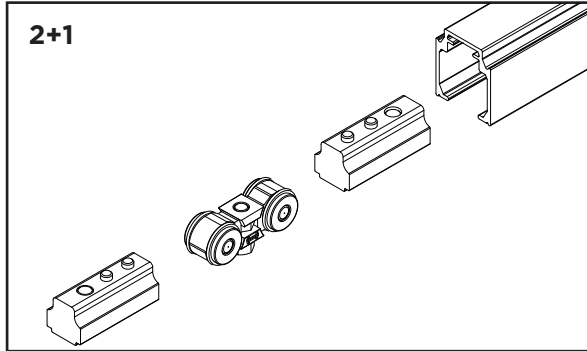

Note: Ensure M8 Nut in Place

6 SECURE TRACK INTO PLACE.

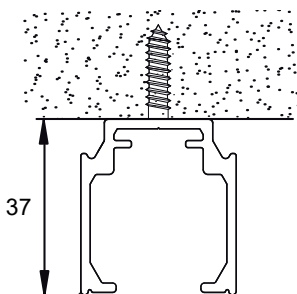

Note: Fixings not provided. Ensure fixings can support system weight.

7 SLIDE PIVOT BLOCK(S) FLUSH TO FRAME. SECURE IN PLACE.

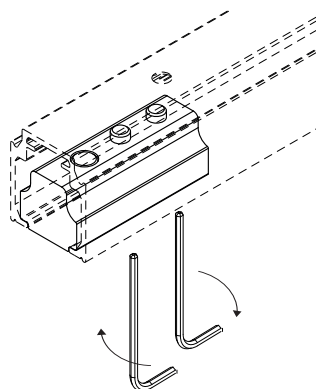

8 POSITION TIMBER HEADER AND PACKER AS PER THE BELOW.

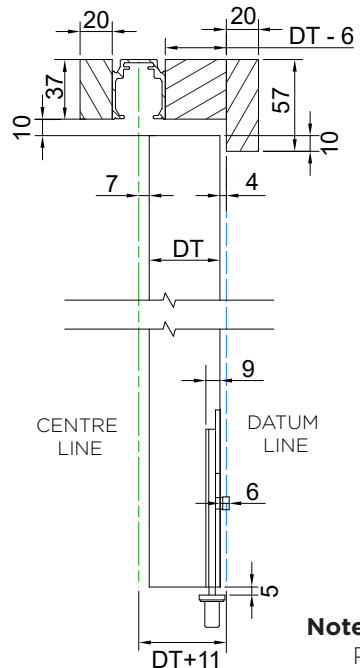

Note: Timber not Provided.

DOORS AND HINGES OVERVIEW

9

FLUSH BOLT ROUTING DETAILS.
SECURE FLUSH BOLTS USING 30MM SCREWS PROVIDED.

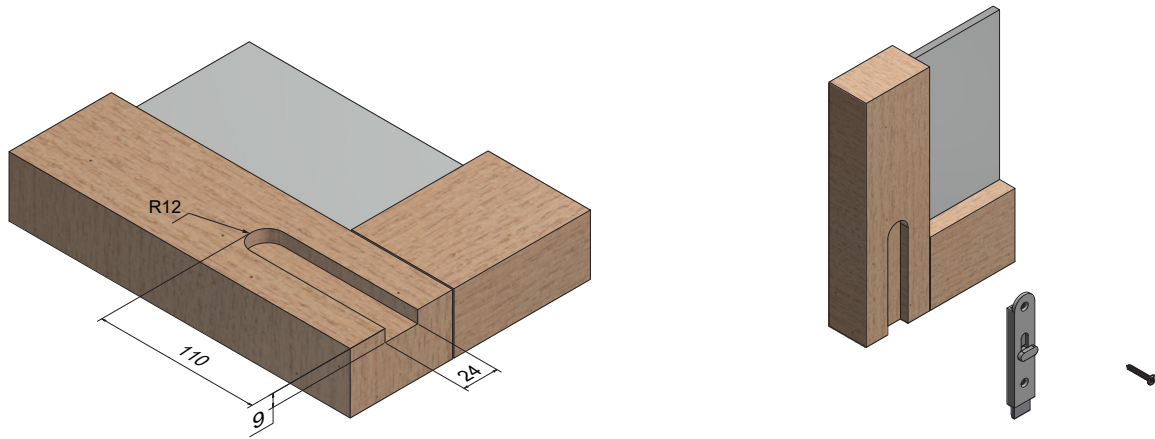

10

FIX RELEVANT HINGES TO DOORS - AS SHOWN BELOW.
NOTE: HINGES TO BE INSTALLED IN ORIENTATION SHOWN.

2+1 Door

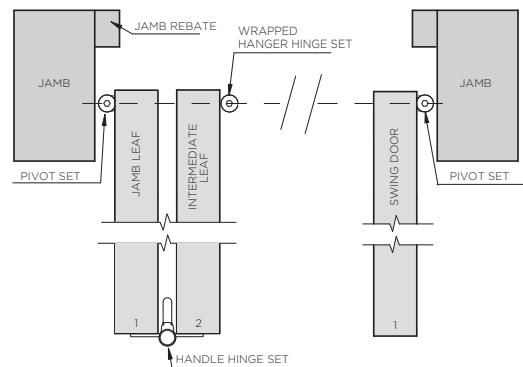
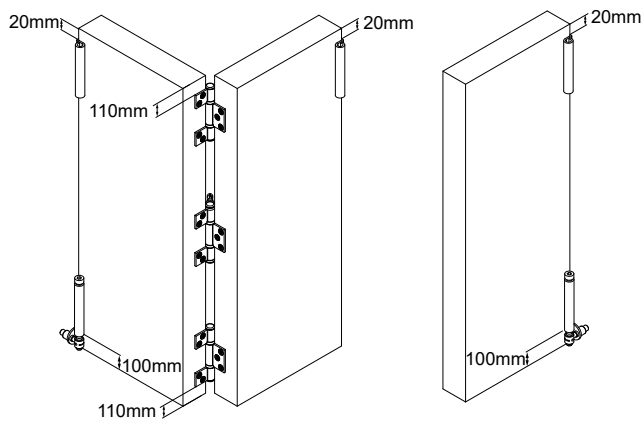

3+0 Door

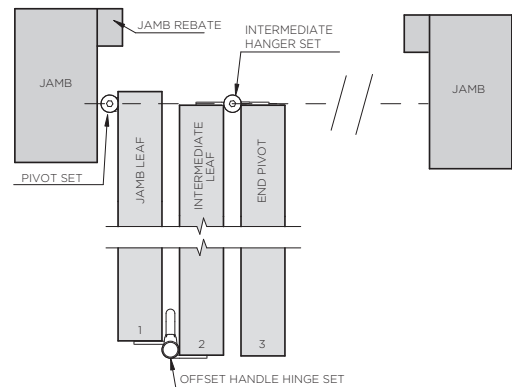
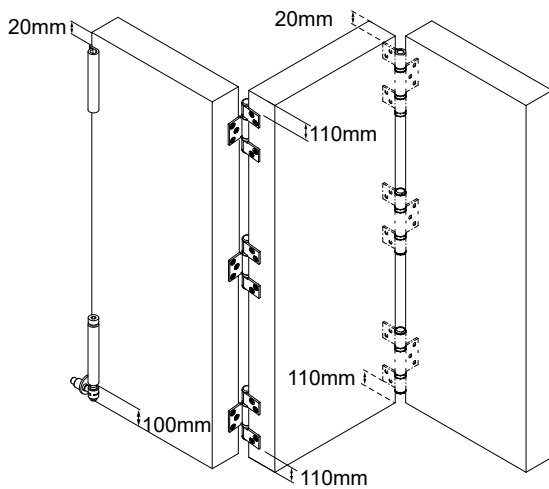

DOORS AND HINGES OVERVIEW CONTINUED

3+1 Door

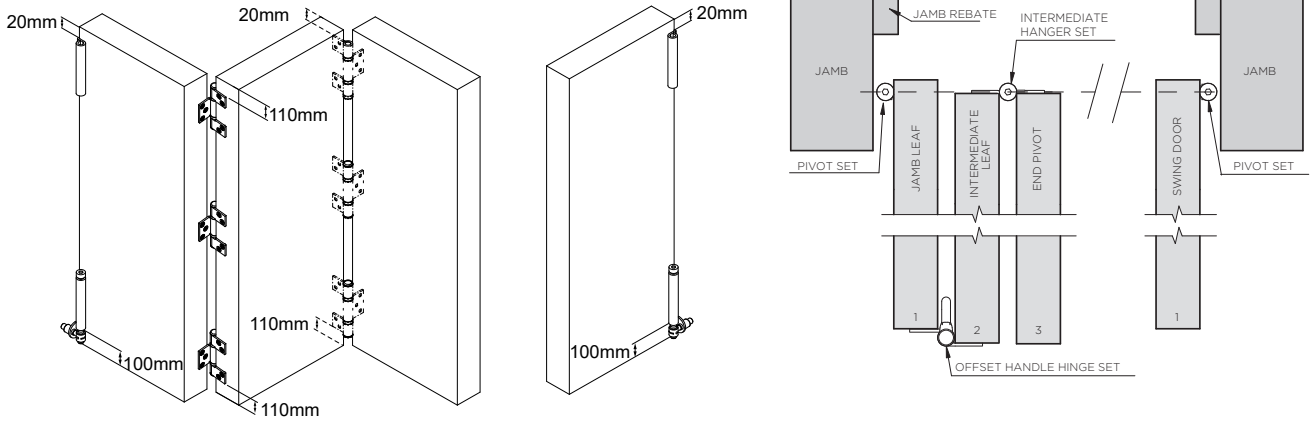

3+2 Door

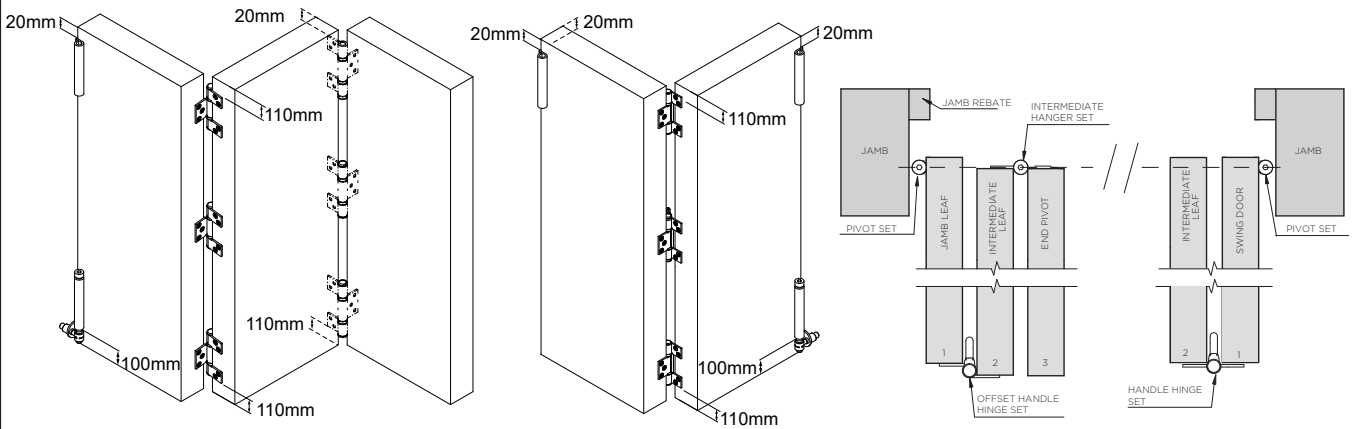

3+3 Door

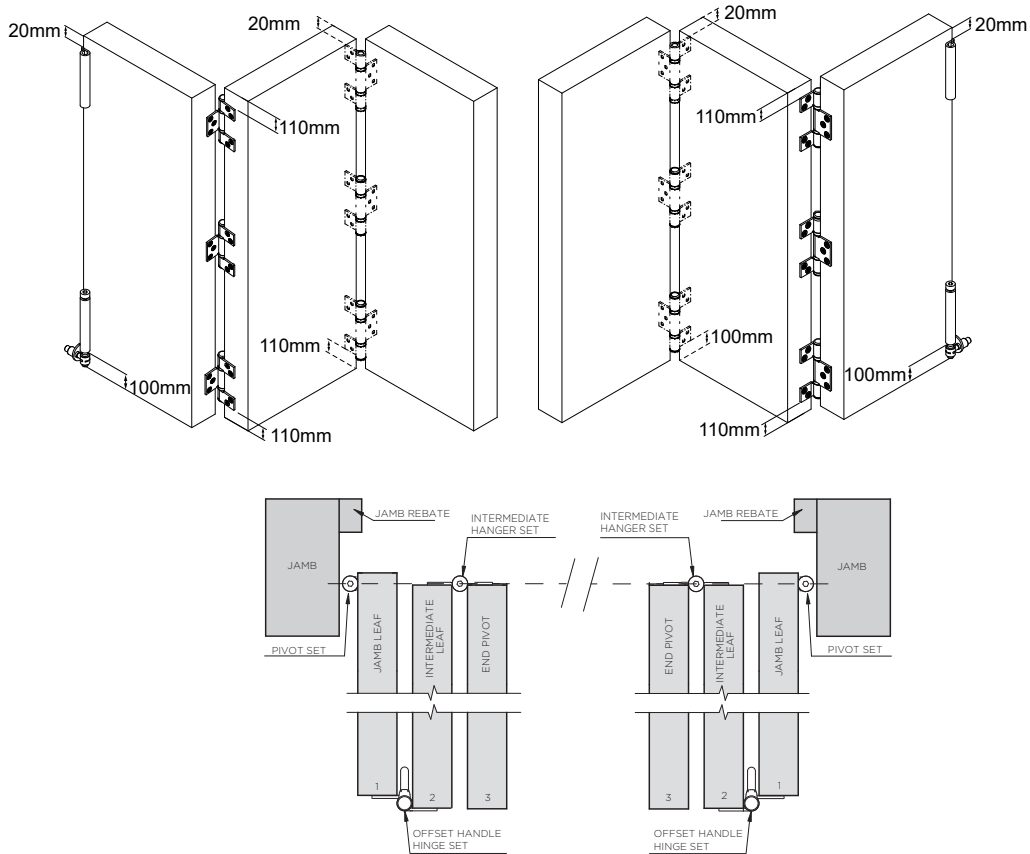

11

DISASSEMBLE
BOTTOM PIVOT.

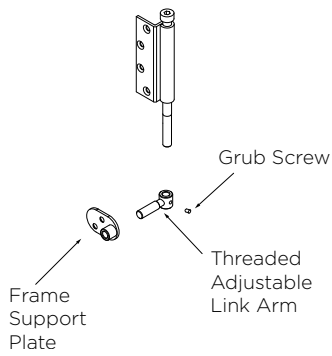

12

FIX FRAME SUPPORT PLATE TO FRAME ON PIVOT DOOR SIDE.
2+1, 3+1, 3+2 AND 3+3 CONFIGURATIONS ONLY:
MIRROR THIS STEP ON OTHER SIDE OF FRAME.

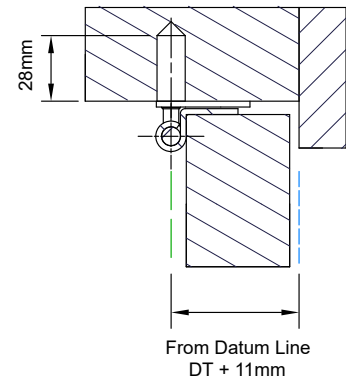
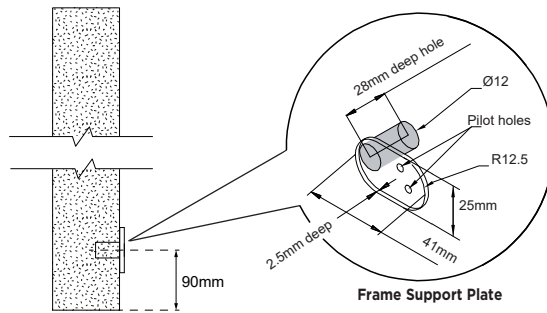

Note: Ensure 12mm diameter hole is inline with centre of track.

13

SCREW LINK ARM INTO FRAME SUPPORT PLATE.

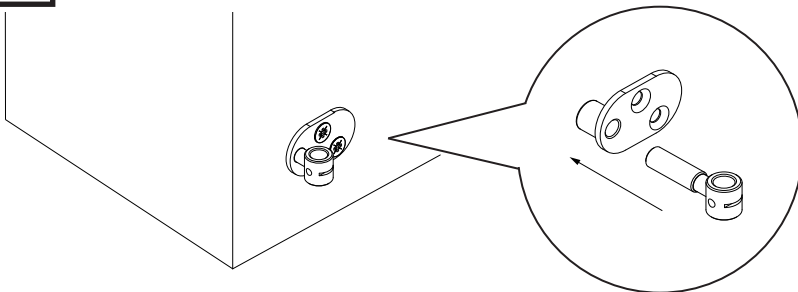

SIDE VIEW

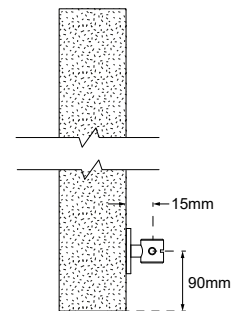

14

RAISE DOOR 1: 5MM FROM FLOOR.
UNSCREW NUT, SLIDE STRAP BOLT
THROUGH HINGE AND REATTACH NUT.
TIGHTEN WITH 5MM ALLEN KEY.

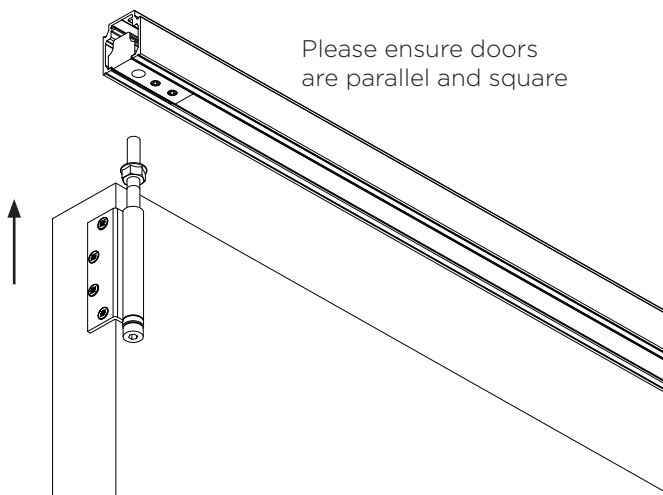

Please ensure doors
are parallel and square

15

SLIDE STRAP BOLT THROUGH
BOTTOM HINGE AND INTO LINK
ARM. TIGHTEN WITH 5MM
ALLEN KEY.

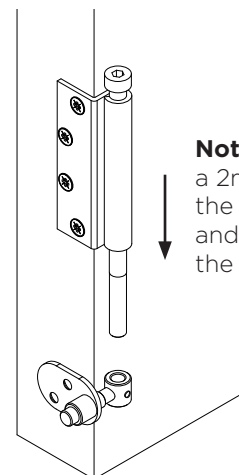

Note: Ensure there is
a 2mm gap between
the top of the hinge
and the bottom of
the strap bolt head.

HANGING A 2 DOOR KIT

16

RAISE DOOR 2: 5MM FROM FLOOR. CONNECT DOORS 1 AND 2 USING REMAINING HINGE LEAF.

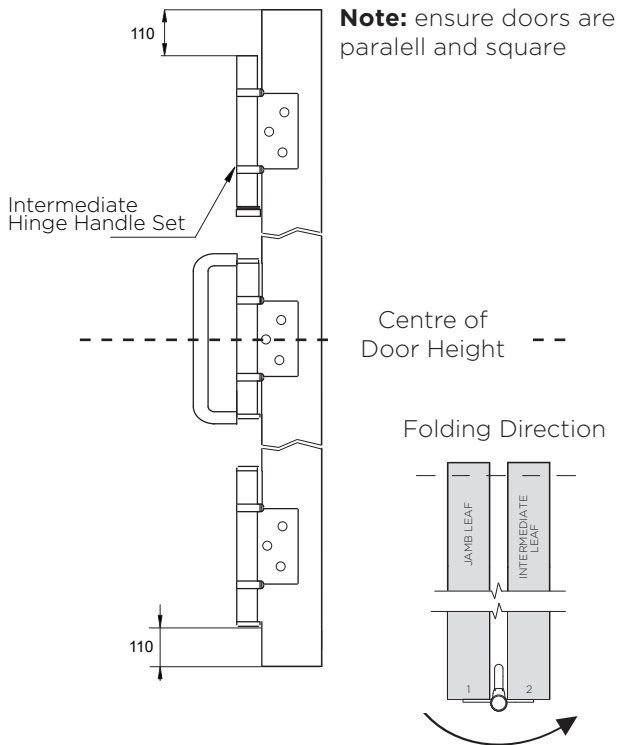

17

CONNECT HANGER BODY TO WRAPPED HINGE ON DOOR 2 USING STRAP BOLT.

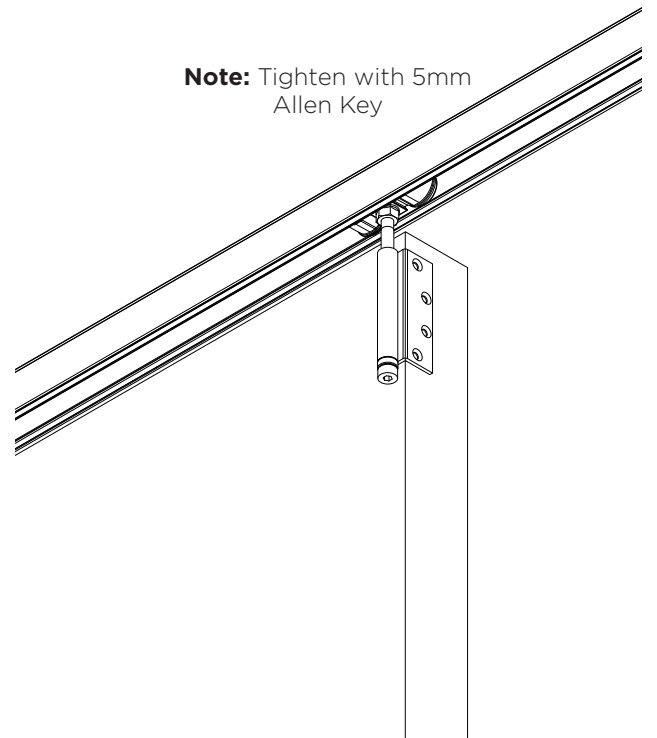

HANGING A 3 DOOR KIT

18

RAISE DOOR 2: 5MM FROM FLOOR. CONNECT DOORS 1 AND 2 USING REMAINING HINGE LEAF.

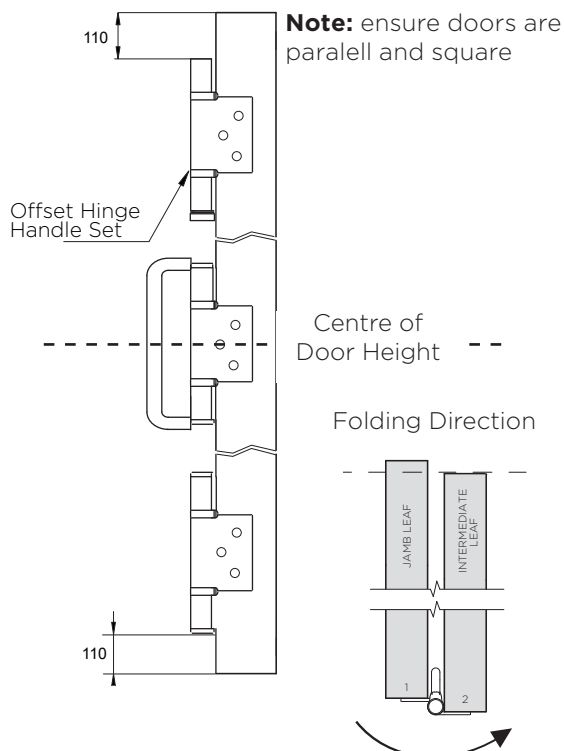

19

RAISE DOOR 3: 5MM FROM FLOOR. CONNECT DOOR 2 & 3 USING INTERMEDIATE HANGER HINGE AND REMAINING HINGE LEAF.

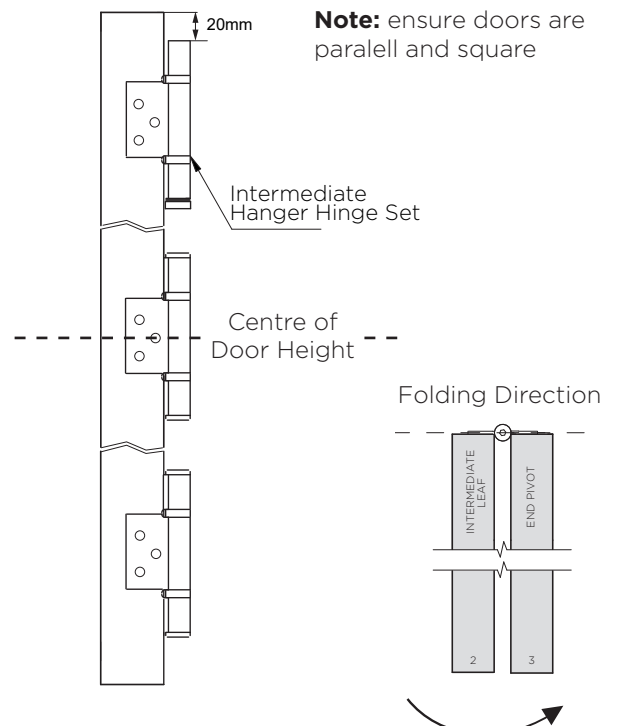

FITTING THE FLUSH BOLTS

20

CLOSE DOORS FLUSH. MARK POSITION OF FLUSH BOLT PIN ON FLOOR. OPEN DOORS. ROUTE FLOOR AREA. FIX FLUSH BOLT KEEP AND PLATE.

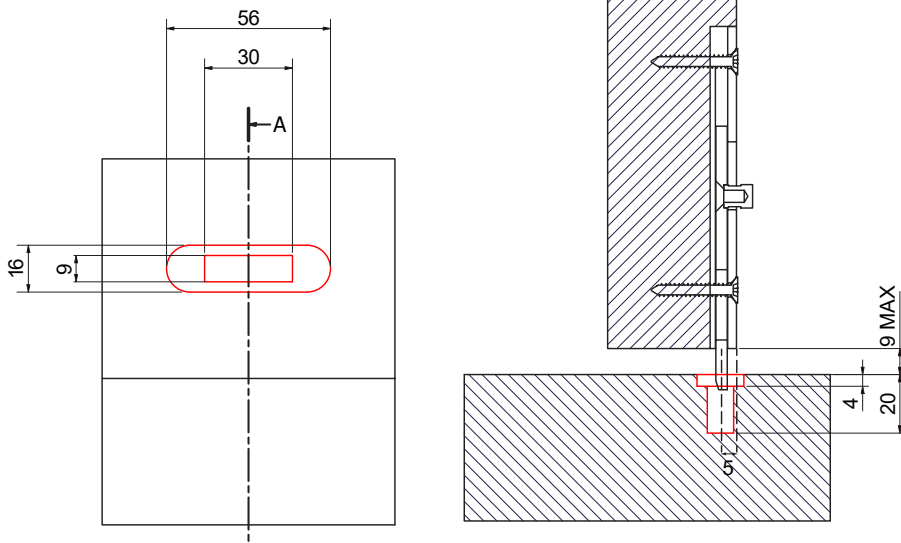

21

HEIGHT ADJUSTMENT. (+/-3MM)

Close all doors and adjust door height for an equal gap between top of door and bottom of track (9mm gap is recommended).

Use 13mm spanner to tighten.

22

INSERT AND TIGHTEN GRUB SCREW.

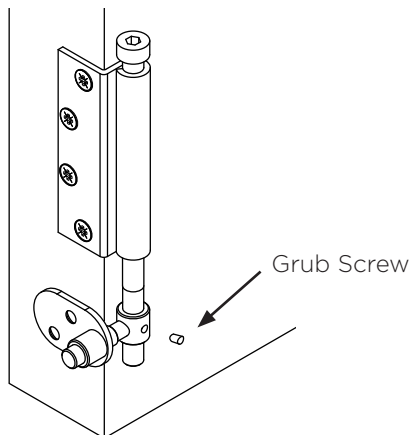

Ensure clearance between pivot door and frame is uniform.

23

CARE AND MAINTENANCE.

Keep track free from dirt and debris.

Periodically replace general purpose grease on bolts.

To prolong the appearance of exposed hinge parts, they can be periodically washed with soap and water.

Maintenance is required on all components including stainless steel to validate manufacturers warranty.

OPERATION INSTRUCTIONS

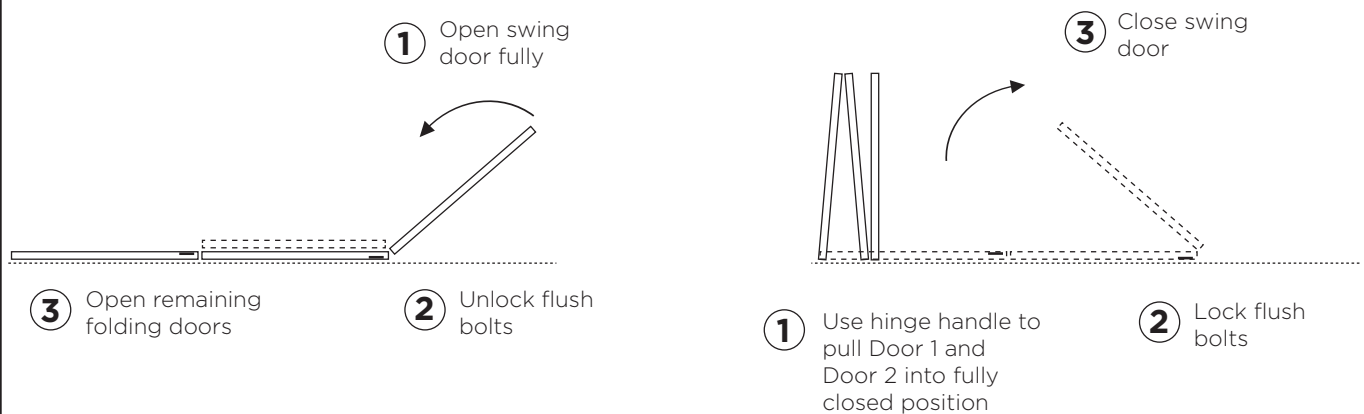

P C HENDERSON LTD

Durham Road, Bowburn,
Co. Durham,
DH6 5NG

UK SALES

t: +44 (0) 191 377 7345
e: sales@pchenderson.com
w: www.pchenderson.com

IRELAND SALES

t: +353 (0)1 643 6816
e: sales@pchenderson.ie
w: www.pchenderson.ie

INTERNATIONAL SALES

t: +44 (0) 191 377 7346
e: international@pchenderson.com
w: export.pchenderson.com

370827

REV 2

Aug-23