



CL500 - 2018 Code Change Instructions



Many codes to choose from

The CL500 code chamber (CL500, CL510, CL520) consists of 11 buttons from which the code is selected, and a 'C' button which is used to re-set the chamber after an incorrect entry, and which must always be used as the first digit of a code. Buttons may only be used ONCE in a code. For example, 1212 is not possible.

A CL500 code, or combination, can be entered in any order or sequence; e.g. 1234 can be 4321 or 1342 or whatever sequence is most convenient to remember. With 11 buttons, a total of 2,047 different codes are available, any of which can be entered in any sequence.

The total is arrived at as follows:

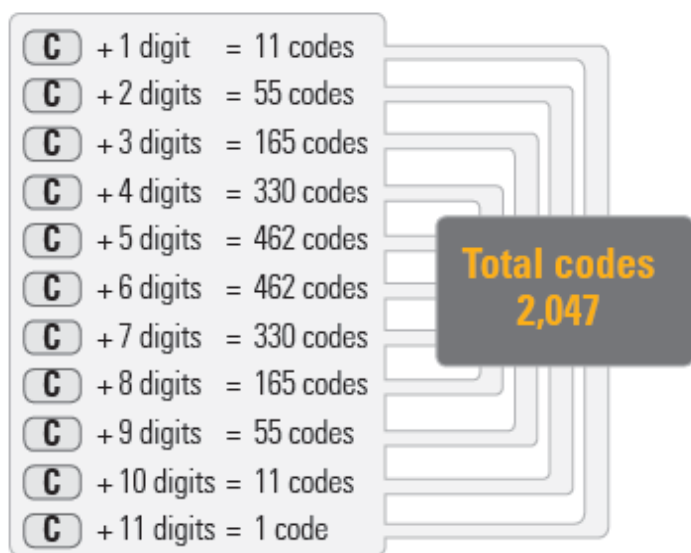

Most people will set a code in the range of 4 to 7 digits, and the total number of codes in this range is 1,584.

The lock is factory set with a randomly selected 5 digit code starting with the C button. The code is not recorded by the factory. The code can be changed as often as required to any other 5 digit code. Every new code must start with the C button. Using the spare tumblers, the code length can be changed to 4 or 6 digits. Shorter codes are possible, but 1 or 2 digit codes are not recommended.

Note: CL505, CL515 and CL525 have 10 coded buttons giving 1,023 different codes.

Code Change Instructions

1. Take your CL500 lock off the door by unscrewing the 2 bolts in the back plate.
2. Press the C button to reset the chamber and place the lock case on a flat surface with the buttons down.
3. Remove the 4 red screws and carefully lift off the code chamber plate. Check that all 12 springs are held in place on the plate.
4. Note that the coloured code tumblers correspond in position to the existing code. The silver non-code tumblers fill the other positions. The C tumbler is not coloured.
5. Hold the lock in your hand and depress the 'C' button. Keeping the 'C' button depressed use tweezers to reposition the tumblers to correspond with your new code. The square notches of ALL tumblers MUST face outwards, with the square tips ON TOP: See diagram below.

DO NOT force the tumblers in.

Note: Holding the C button depressed whilst removing or replacing the tumblers is ESSENTIAL to avoid damaging the internal mechanism. DO NOT attempt to reposition the C tumbler.

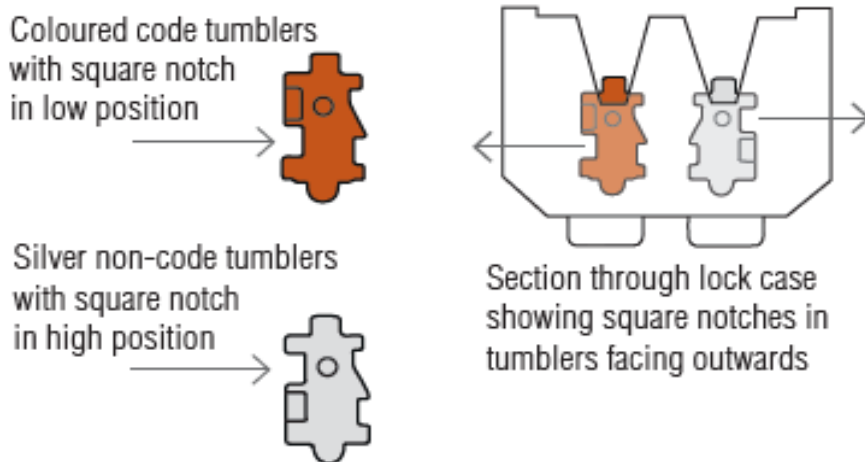

6. Replace the code chamber plate carefully with the 4 red screws.
7. Check the operation of the new code, and make a written note of it before reinstalling the lock.
8. (See below)



For door hung on RIGHT fit silver spindle on code side.



For door hung on LEFT fit coloured spindle on code side.



Fit the butterfly spindle to the inside, non-code side.

Maintenance

No maintenance of the working parts is necessary. **DO NOT OIL.** To maintain the finish the lock should be cleaned regularly with a soft cloth. A silicone spray or similar should be used to provide a protective film against grit and grime.

Guarantee

If any Codelocks mechanical lock should develop a fault, at any time due to manufacturing, just call the Codelocks helpline and arrange for it to be repaired free of charge.

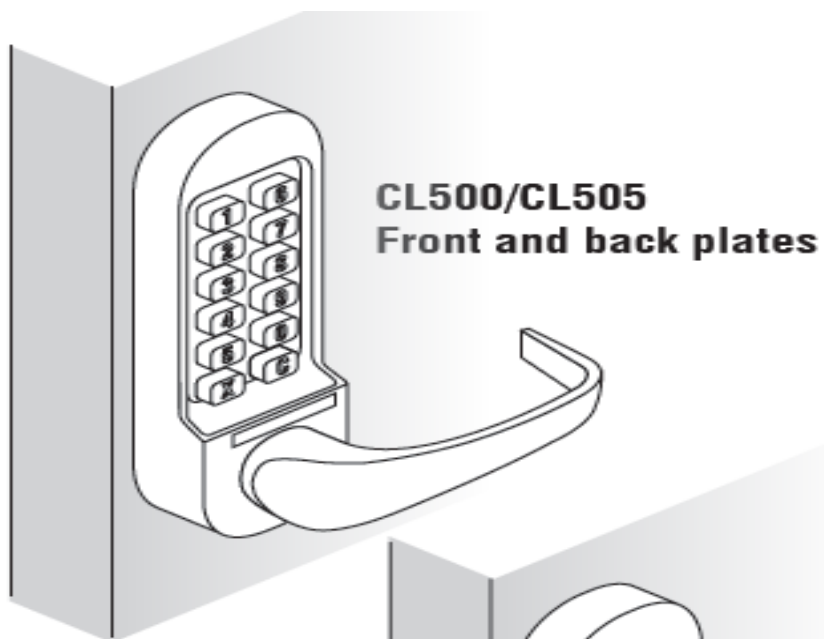

CL510/CL515
mortice latch

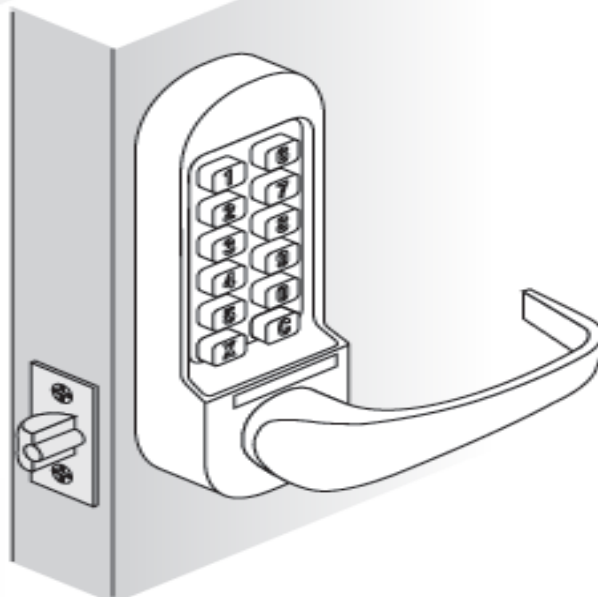

CL520/CL525
mortice lock

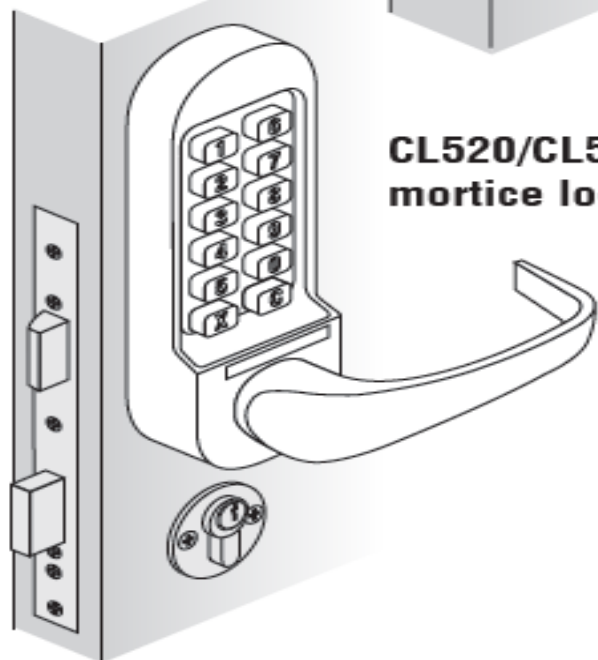

* **Please note:** Model numbers ending with a 5 are not illustrated above.

Features

- Code Free Access mode is available on locks CL505, CL515 and CL525. This is signified by a button with a black dot.
- Inside handle always retracts the latch for exit.
- Weather resistant.
- Vandal resistant, with stainless steel buttons, and clutch protection if the outside handle is forced.
- Reversible handles.
- Fits doors between 35mm (1 3/8") and 60mm (2 3/8") thick without modification.

Back to back version only

- Two coded plates are provided to allow coded access in both directions.
- Butterfly spindle not required.
- For doors hung on the right, fit the silver spindle in the front keypad and the coloured spindle in the opposite side.
- For doors hung on the left, fit the coloured spindle in the front keypad and the silver spindle in the opposite side.

CL520/CL525 ONLY

- Split follower lock enables inside handle to retract latch and deadbolt simultaneously, satisfying 'means of escape' requirements for exit at all times. Prevents accidental lock-ins.
- Deadbolt thrown by key to lock out code users after work hours.
- Key will retract the latchbolt giving access for admin functions.
- Double euro profile cylinder with 3 keys.
- Any euro profile cylinder may be used.
- On multiple door installations consideration should be given to having all cylinders keyed alike, with restricted key issue, for ease of management.

Models

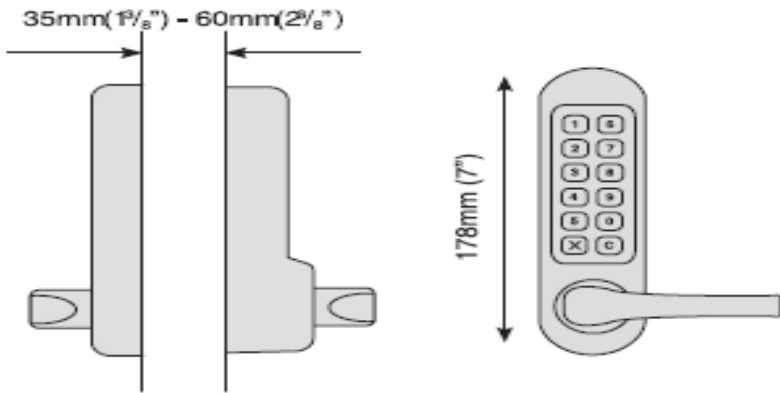

CL500/CL505 for use with existing lock

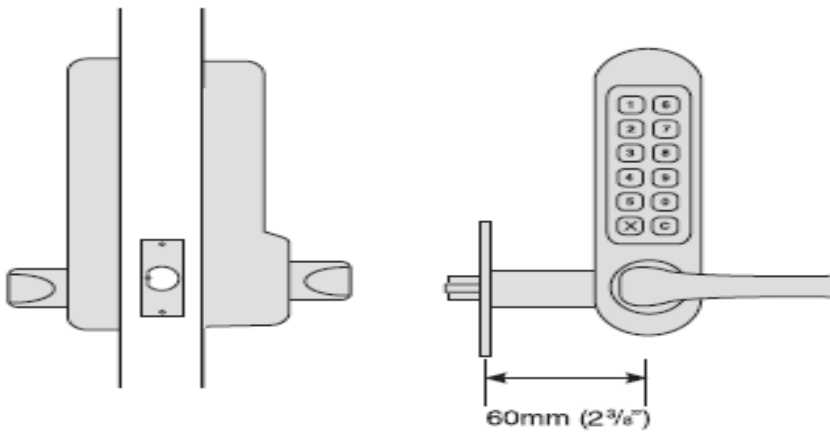

CL510/CL515 with tubular latchbolt

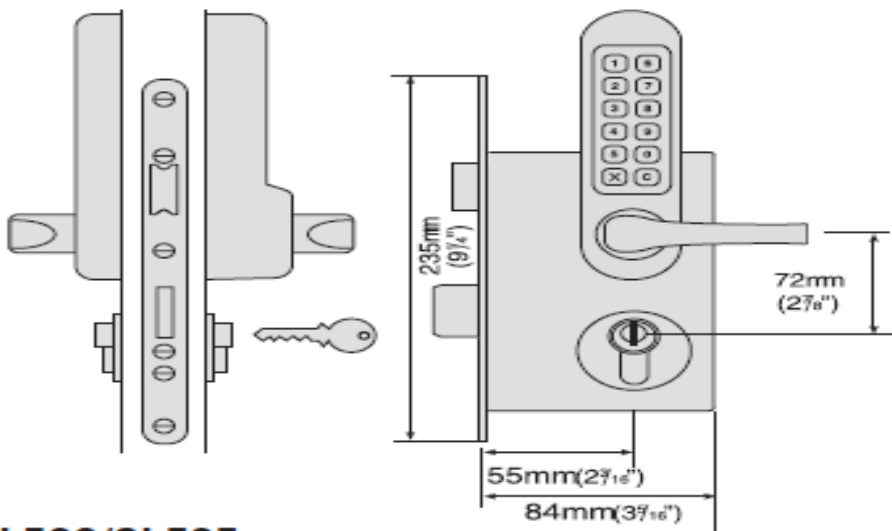

CL520/CL525
with full Panic Function mortise lock and cylinder

* **Please note:** Model numbers ending with a 5 are not illustrated above.

