

# VIPER MULTIPOINT DOOR LOCK

FOR FRONT + FRENCH DOORS

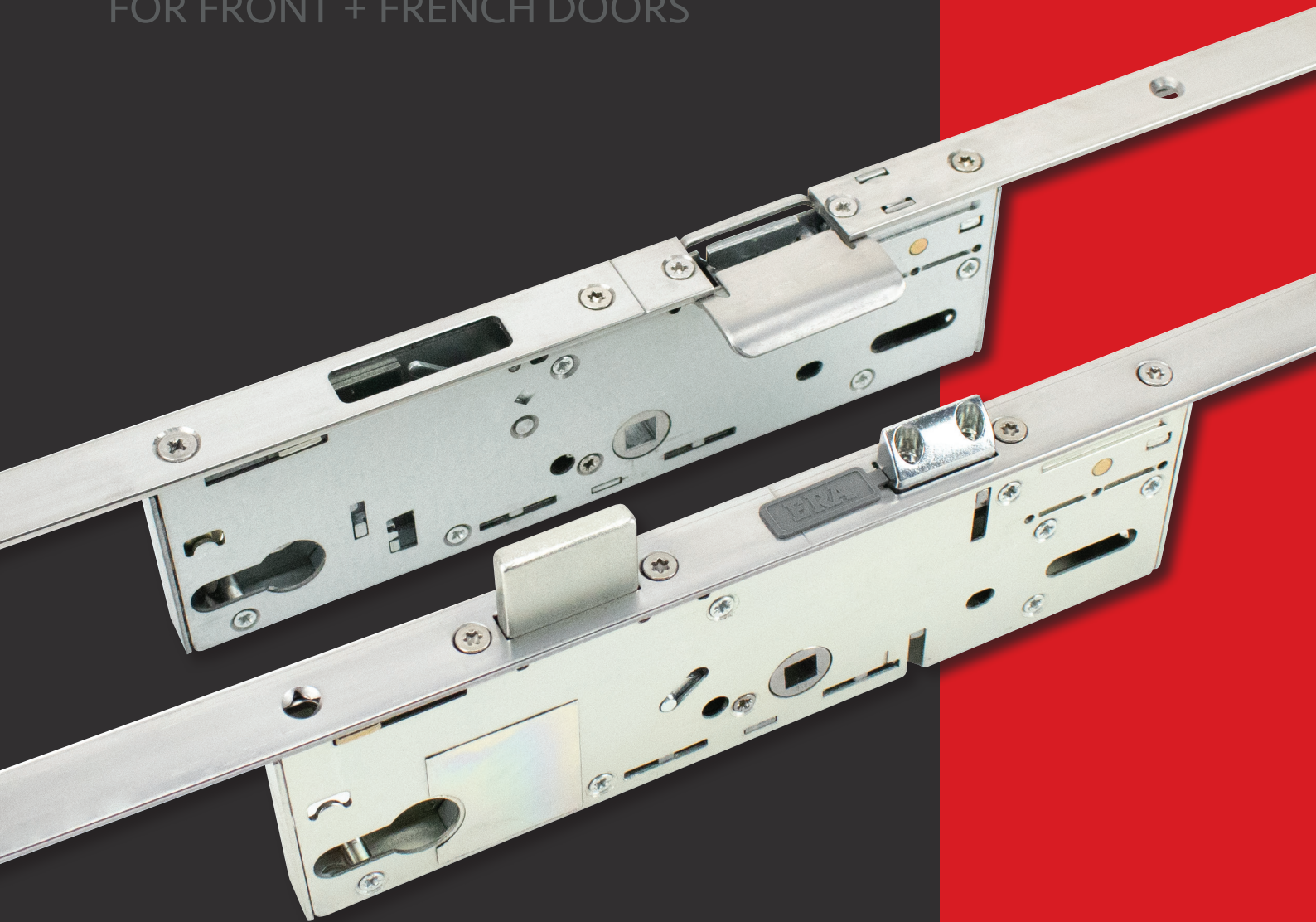

The **ERA Viper Multipoint Door lock** is the best multipoint lock on the market and used by top joineries throughout the UK. It is the perfect solution for single and french doors, with major benefits over other locks. With this lock and its various extension and shoot bolt options, you can manufacture short door heights and tall door heights using the same lock. Please see below some of the key reasons to use this lock when manufacturing Front Entrance and French Doors.

## KEY REASON TO USE THE VIPER MULTIPOINT DOOR LOCK

- ✓ 1870mm minimum height for fully shot french doors.
- ✓ PAS24 accredited for single and french doors to achieve Part Q compliance.
- ✓ Face plate and drive bar manufactured in Stainless Steel.
- ✓ Bi-directional gearbox.
- ✓ Easy installation with full flush adjustment on every locking point.
- ✓ Double laminated security shootbolts on master and slave doors.
- ✓ Both locks split spindle as standard which saves on setup time.
- ✓ 45mm backset for slave and master.



SASH + DOOR  
HARDWARE

# Viper French & Single Door Lock



## KEY FEATURES

- Face plate and drive bar manufactured in Stainless Steel.
- 3 x 20mm brass forged tapered deadbolts.
- Full flush adjustment on every locking point.
- Extension with deadbolt (Master) and adjustable keep (Slave) for taller french and front doors.
- Double laminated security shootbolts on master and slave doors for extra security.
- 45mm backset for slave and master lock.
- Adjustable flush strike plates with 20mm face plate.
- Both locks split spindle as standard which saves on setup time.
- Bi-directional gearbox.
- Anti-fouling device fitted to slave lock ensuring you lock the master before the slave.
- Slave has an adjustable strike for centering of 56 - 58mm doors.
- 1870mm minimum height with handle height of 1050mm for fully shot french doors. Shorter doors can be achieved if reducing handle height or not fitting a top shoot bolt.
- PAS24 accredited for single and french doors as well as being Part Q compliant.
- Adjustable range of single door keeps for 56mm doors or use single piece keep.
- Achieved PAS24 2016 test

## DOOR SIZING CHART

	VIP45M	VIP45S	VIPMED	VIPSEK	VIP152SB	VIP352SB	TDBTSBK
1815-2100	1	1			4		2
2100-2300	1	1			2	2	2
2300-2670	1	1	1	1	4		2
2450-2880	1	1	1	1	2	2	2

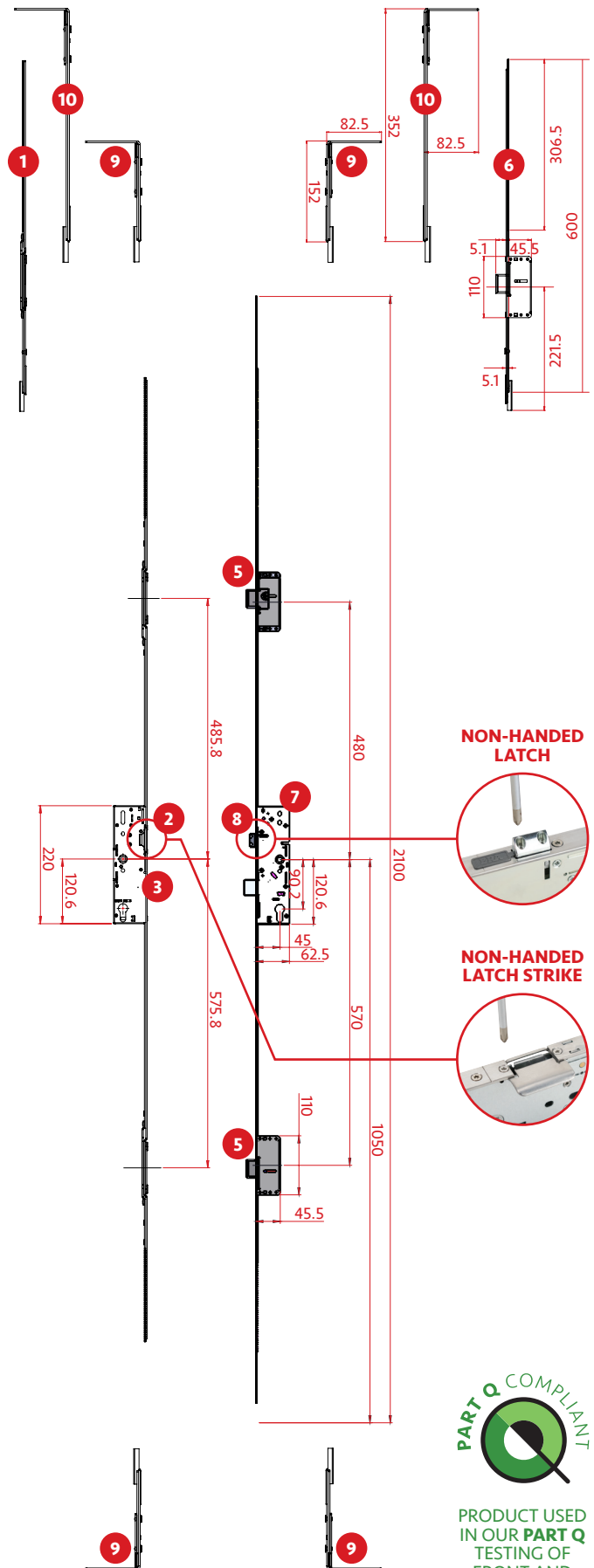

PRODUCT USED IN OUR PART Q TESTING OF FRONT AND FRENCH DOORS



ORDER NOW ON: 01752 651330 FAX: 01752 253823

## 1 SLAVE EXTENSION

TDKASEX

600mm Slave Extension with integral adjustable keep for master extension



## 6 MASTER EXTENSION

TDKAMEX

600mm Master Extension with integral high security forged brass linear bolt.



## 2 LATCH STRIKE

Adjustable centre latch strike to suit a centre lock position on a 56mm door. On thicker doors use an offset lock. Alternatively call our sales team to discuss a bespoke latch strike.

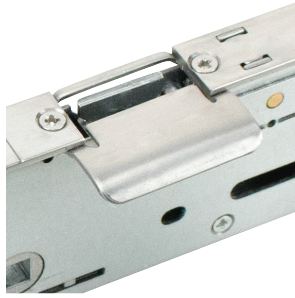

## 7 SPLIT SPINDLE OPTION

Master lock has a split spindle option as standard with a snib facility for de-latching (below).



## 3 ANTI-FOUL DEVICE

Feature that ensures the slave lock is thrown before the master lock is secured.



## 8 SNIB FACILITY

Snib facility for de-latching



## 4 DEADBOLT STRIKE

Fully adjustable flush deadbolt strikes with +/- 2mm of adjustment.



## 9 DOUBLE LAMINATED SHOOTBOLT

TDKACS2

Extra enhanced security shootbolt for improved resistance to forced entry.



## 5 TAPERED DEADBOLT

2 x high security forged linear bolts with 2mm throw and tapered lead in.



## 10 EXTENDED SHOOTBOLT

TDKVTSBEX

For doors heights between 2100mm and 2280mm.

Double Laminated.



**Whitehill**

TALK TO US  
ABOUT TOOLING  
FROM WHITEHILL

## LOCKING SYSTEM FOR **SINGLE** REBATED DOORS

DEV-124-15 DEVENTER WEATHERSEALS

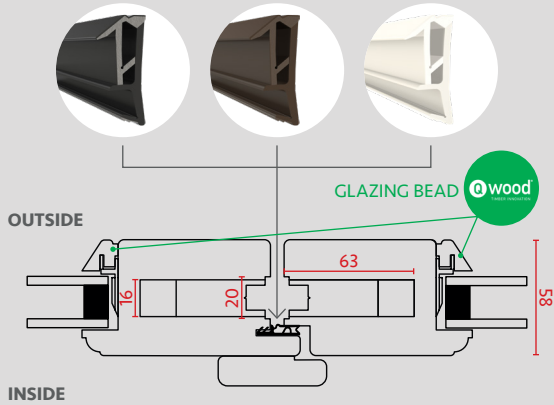

## LOCKING SYSTEM FOR **DOUBLE** REBATED DOORS

This rebate section will save time as the Slave & Master profiles are the same

DEV-124-15 DEVENTER WEATHERSEALS

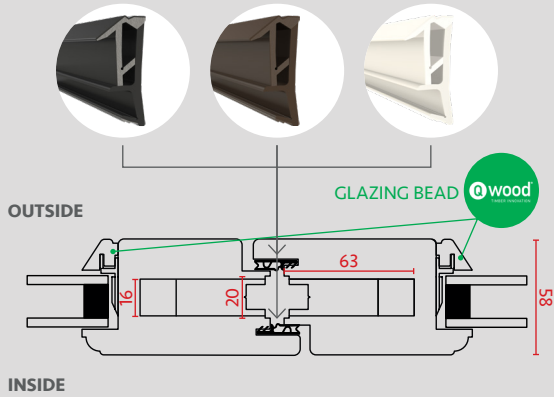

## LOCKING SYSTEM FOR **SQUARE EDGE** DOORS

FT10 FOAMTEQ WEATHERSEAL

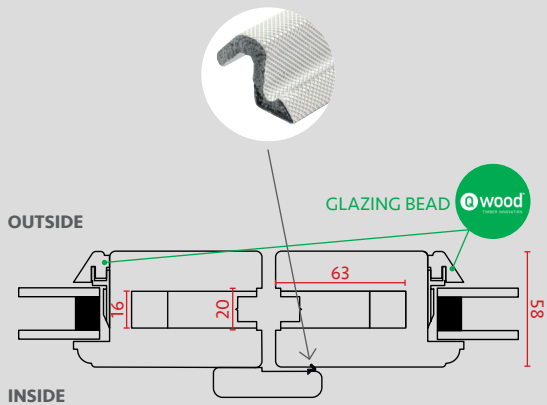

## KEEPS FOR **SINGLE** DOORS

CHOICE OF ONE PIECE KEEP

OR

SEPERATE MASTER AND HOOK KEEPS

TDBKHOOK



TDBK56 & TDBKBASE



TDBKHOOK

